

NOSE ASSEMBLY DATA SHEET

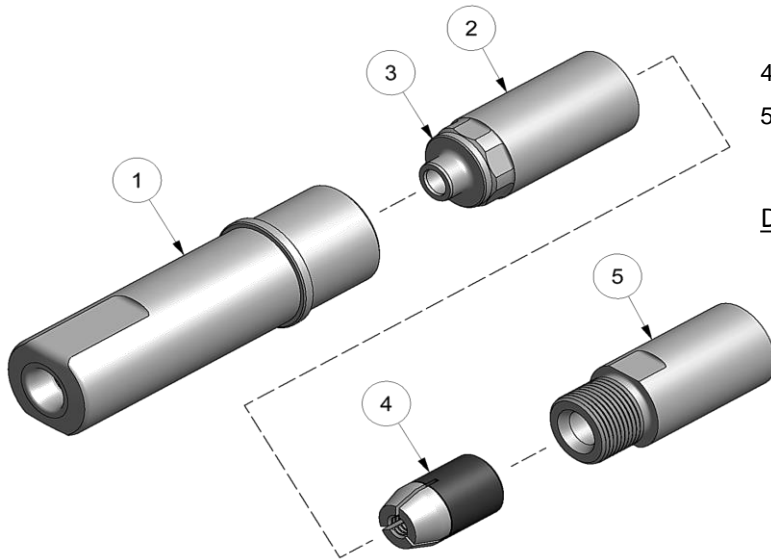
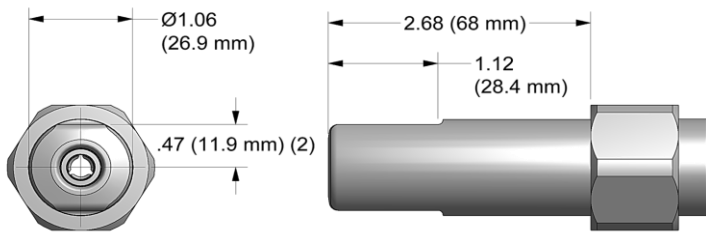

ASSEMBLY:

Note: If nose assy is assembled as it is when purchased new, follow steps 3-5 to attach to tool.

1. Insert super grip jaw assy (4) into rear of collet assy (2). (Note direction in exploded view).
2. Thread collet assy (2) to extension-collet (5) using flats provided. Insert ejector (3) into front i.d. of collet (2).
3. Thread assembled collet (2) and extension-collet (5) onto piston of tool using flats provided and hex in rear of piston.
4. Slide anvil assy (1) over collet (2).
5. Slide retaining nut over anvil (Note: retaining nut stop not used on this nose assy) and tighten to tool.

DISASSEMBLY:

Reverse assembly instructions.



10/06 REV 1/18

GAGE BILT
MADE in USA

44766 Centre Court Clinton Twp. MI 48038 USA
Ph: +1 (586) 226-1500 Fax: +1 (586) 226-1505
solutions@gagebilt.com / www.gagebilt.com

Type:		Fastener:	Recommended Tool: GB756
Non Self-Releasing 5/16 Ø		BOM®	Alternate Tools: GB2581(A)
Ref. No.	Qty.	Description	BOM10-756-26
1	1	Anvil Assy	11005
2	1	Collet Assy (Includes #3)	21024
3	1	Ejector	81009-1
4	1	Super Grip Jaw Assy	30869-S1
5	1	Extension-Collet	71219