

ORIGINAL INSTRUCTIONS

GB107 SERIES

20V BATTERY INSTALLATION TOOL



GB107 SERIES	
GB107	Includes (1) VP1086 (2Ah Battery)
GB107/2	Includes (2) VP1086 (2Ah Batteries)

Registered to
ISO 9001:2015

GAGE BILT
 **MADE in USA**

DISTRIBUTED BY

ADVANCE 
COMPONENTS

advancecomponents.com 972-446-5500

TABLE OF CONTENTS



	<u>Page</u>
Warranty	3
Description and Technical Specifications	4
Description of Functions	5
Warnings.....	6
Principle of Operation.....	7
How to set-up the GB107.....	8-10
How to use the GB107	11
Maintenance	12
Troubleshooting.....	13
Parts Lists.....	14
Alternate Tools / Accessories	16



WARRANTY

Seller warrants that all goods covered by this catalog will conform to applicable specifications and will replace or repair, EXW our plant, any goods providing defective from faulty workmanship, or material, for 1 year from date of shipment.

Said warranty to remain in effect if, and only if, such goods are used in accordance with all instructions as to maintenance, operation and use, set forth in manuals and instruction sheets furnished by seller.

Sellers obligation under this warranty shall be limited to the repair or rework of the goods supplied or replacement thereof, at Seller's option, and in no case is to exceed the invoice value of said goods. Under no circumstances will the seller be liable for incidental or consequential damages or for damages incurred by the buyer or subsequent user in repairing or replacing defective goods or if the goods covered by this warranty are reworked or subjected to any type of additional processing.

This warranty is void if Seller is not notified in writing of any rejections or defects within 1 year after the receipt of the material by the customer.

Tool should not be opened during warranty period. This may void the warranty.

THIS WARRANTY IS MADE IN LIEU OF ALL OTHER WARRANTIES EXPRESSED OR IMPLIED, INCLUDING MERCHANTABILITY.

DESCRIPTION



WARNING: Any other use is forbidden.

The GB107 is a battery operated 20V installation tool designed specifically for the efficient installation of 3/32" (2.4 mm) thru 3/16" (5.0 mm) blind rivets. It weighs just 3.5 lbs. (1.6 kg) and can be operated in any position. It has a .984" (25 mm) fastener setting stroke and a rated pull load of 2,248 lbs. (10 kN).

ENVIRONMENTAL USE

WARNING: Do not operate in an explosive atmosphere.

The GB107 can be operated between 23°F - 113°F (-5°C - 45°C)



SPECIFICATIONS

Weight (Incl. battery)	- 3.5 lbs. (1.6 kg)
Drive (DC / BLDC)	- DC
Sound Emissions (LpA / K // LWA / K [dB])	- <65 / 3 // <76 / 3
Vibrations ah / K [m/s ²]	- <2.5 / 1.5
Service interval (# of fasteners)	- 100,000
Total Stroke	- .984" (25 mm)
Rated Pull Load	- 2,248 lbs. (10 kN)
Battery [V]	- 20
Battery [Ah]	- 2 Ah/ 4 Ah
Battery Cells (Number)	- 4
Battery weight	- .32 lbs. (0.145 kg)
Battery working temp. [°F-°C]	- 23°F - 113°F (-5°C - 45°C)
Charger Input Voltage [V AC / Hz]	- 100 to 240 / 50 to 60
Charger Output Voltage [V DC]	- 7.0 to 21.0
Charger Output Current [Ah]	- 4
Charger Working Temp. [°F-°C]	- 32°F - 104°F (0°C - 40°C)
Charger charging time to 90% / 100%	- 22 / 30 minutes
Charger weight w/o cable	- .55 lbs. (0.25 kg)



TERMS AND SYMBOLS



- Product complies with requirements



- Hearing protection and eye protection



- Read manual prior to using equipment



- Wear safety boots



WARNINGS - Must be understood to avoid severe personal injury.



CAUTIONS - show conditions that will damage equipment and/or structure.

Notes - are reminders of required procedures.

GENERAL SAFETY RULES:

1. For multiple hazards, read and understand the safety instructions before installing, operating, repairing, maintaining, changing accessories on, or working near the assembly power tool for non-threaded mechanical fasteners.
2. Only qualified and trained operators should install, adjust or use the assembly power tool for non threaded mechanical fasteners.
3. Do not modify this assembly power tool for non-threaded mechanical fasteners. Modifications can reduce effectiveness of safety measures and increase the risks to the operator.
4. Do not discard safety instructions; give them to the operator.
5. Do not use assembly power tool for non-threaded mechanical fasteners if it has been damaged.
6. Tools shall be inspected periodically to verify all ratings and markings required are legible. The employer/user shall contact the manufacturer to obtain replacement marking labels when necessary.

PROJECTILE HAZARDS:

1. Disconnect the tool from the energy source when changing inserted tools/nose assemblies or accessories.
2. Be aware that failure of the workpiece or accessories, or even the inserted tool/nose assembly itself can generate high-velocity projectiles.
3. Always wear impact resistant eye protection during operation of the tool. The grade of protection required should be assessed for each use.
4. The risk to others should also be assessed at this time.
5. Ensure that the workpiece is securely fixed.
6. Check that the means of protection from ejection of fastener and/or stem is in place and operative (such as the deflector or collection bottle).
7. If the mandrel collecting containers can be fitted, ensure they are properly connected and used correctly. By-passing of the safety switch is prohibited.
8. Forcible ejection of the mandrel from the front of the nose assembly is possible.

ELECTRICAL HAZARDS:

1. The plug must not be altered in any way. Do not use adapter plugs in conjunction with earthed fast chargers.
2. Avoid physical contact with ungrounded surfaces, such as pipes, heaters, cookers or refrigerators.
3. Keep installation tools away from water or rain. The ingress of water into the installation tool increases the risk of electrical shock.
3. Do not misuse the cable, e.g. for carrying or hanging the fast charger or for pulling the plug out of the socket. Keep the cable away from heat, oil, sharp edges or moving parts. Damage or twisted cables increase risk of electric shock.
4. When using the installation tool outdoors, use for the fast charger only extension cords that are also suitable for outdoor use. This will reduce risk of electric shock.
5. If the use of the installation tool in a damp environment is unavoidable, use for the fast charger a residual current circuit breaker to avoid risk of shock.
6. The plug of the setting tool must fit properly into the plug socket. Modified plugs and non matching plug sockets increase the risk of an electric shock.

OPERATING HAZARDS:

1. Use of tool can expose the operator's hands to hazards, including crushing, impacts, cuts, abrasions and heat. Wear suitable gloves to protect hands.
2. Operators and maintenance personnel shall be physically able to handle the bulk, weight and power of the tool.
3. Hold the tool correctly; be ready to counteract normal or sudden movements and have both hands available.
4. Maintain a balanced body position and secure footing.
5. Release the start-and-stop device in the case of interruption of energy supply.
6. Use only lubricants recommended by the manufacturer.
7. Avoid unsuitable postures as it is likely for these positions not to allow counteracting of normal or unexpected movement of the tool.
8. If the tool is fixed to a suspension device, make sure that fixation is secure.
9. Beware of the risk of crushing or pinching if nose equipment is not fitted.
10. Due to the tool weight, it is recommended safety shoes be worn during operation.
11. It is recommended tool be operated not more than 50 out of every 60 minutes, where prolonged use is expected.

REPETITIVE MOTIONS HAZARDS:

1. When using the tool, the operator can experience discomfort in the hands, arms, shoulders, neck or other parts of the body.
2. While using the tool, the operator should adopt a comfortable posture while maintaining a secure footing and avoiding awkward or off balanced postures. The operator should change posture during extended tasks; this can help avoid discomfort and fatigue.
3. If the operator experiences symptoms such as persistent or recurring discomfort, pain, throbbing, aching, tingling, numbness, burning sensations or stiffness, these warning signs should not be ignored. The operator should tell the employer and consult a qualified health professional.

ACCESSORY HAZARDS:

1. Disconnect tool from energy supply before changing the nose assembly or accessory.
2. Use only sizes and types of accessories recommended by the manufacturer. Do not use other types or sizes of accessories.

WORKPLACE HAZARDS:

1. Do not work with the installation tool in a potentially explosive atmosphere where there may be flammable liquids, gases or dusts. Installation tools generate sparks that could ignite dusts or vapors.
2. Keep children and other persons away when working with the installation tool. If distracted, you may lose control of the installation tool.
3. Do not use the installation tool when you are tired or under the influence of drugs, alcohol or medication. Severe personal injury could result.
4. Be careful, pay attention to what you are doing and work sensibly when using the installation tool.

NOISE HAZARDS:

1. Exposure to high noise levels can cause permanent, disabling hearing loss and other problems, such as tinnitus (ringing, buzzing, whistling or humming in the ears). Therefore, risk assessment and the implementation of appropriate controls for these hazards are essential.
2. Appropriate controls to reduce the risk may include actions such as damping materials to prevent workpieces from "ringing".
3. Use hearing protection in accordance with employer's instructions and as required by occupational health and safety regulations.
4. Operate and maintain the assembly power tool for non-threaded mechanical fasteners as recommended in the instruction handbook, to prevent an unnecessary increase in the noise level.
5. Select, maintain and replace the consumable/inserted tool as recommended in the instruction handbook, to prevent an unnecessary increase in noise.
6. If the power tool has a silencer, always ensure that it is in place and in good working order when the power tool is being operated.

VIBRATION HAZARDS:

1. Exposure to vibration can cause disabling damage to the nerves and blood supply of the hands and arms.
2. Wear warm clothing when working in cold conditions and keep your hands warm and dry.
3. If you experience numbness, tingling, pain or whitening of the skin in your fingers or hands, stop using the assembly power tool for non-threaded mechanical fasteners, tell your employer and consult a physician.
4. Support the weight of the tool in a stand, tensioner or balancer, because a lighter grip can then be used to support the tool.

PRINCIPLE OF OPERATION



When the battery is connected to the tool, operation is controlled by an actuator to the motor. The GB107 incorporates an electronic actuator assembly to send a signal to the motor. When the actuator assembly is depressed, the gear on the motor spins the gear on the gear box assembly retracting the nose assembly collet. This action causes the jaws to clamp on the fastener pintail and pull the sheets together. Further force breaks the pintail off. When the actuator is released, the tool moves back to its starting position. The spent pintail is released and drops out the back of the tool.



HOW TO SET-UP THE GB107



- ⚠ WARNING:** Only qualified and trained operators should install, adjust or use the installation power tool for all fasteners.
- ⚠ WARNING:** Operator **MUST** read and understand all warnings and cautions.
- ⚠ WARNING:** It is required that eye protection, hearing protection and safety boots be worn at all times while handling this equipment.
- ⚠ WARNING:** The users or the user's employer should assess specific risks that could be present before each use based on their application.
 - *Be sure there is adequate clearance for tool and operator's hands before proceeding. Keep fingers clear of any moving parts. Keep fingers clear from fasteners and installed materials. Severe personal injury may result.*
 - *Ensure that there are no electrical cables, gas pipes, etc., which can cause a hazard if damaged by the tool.*
- ⚠ WARNING:** Do not pull fastener in the air. Personal injury from fastener ejecting may occur.
- ⚠ WARNING:** Do not use as a hammer. If improperly used or damaged, liquid can escape from the battery causing skin irritations or burns. Wash with water or seek medical attention immediately if liquid gets into eyes or burns occur.
- ⚠ WARNING:** Do not use in explosive atmosphere.
- ⚠ WARNING:** Charge the batteries only in chargers recommended by the manufacturer. Risk of fire or explosion if batteries used on non manufacturer chargers.
- ⚠ WARNING:** Use only the specified batteries in the tool. The use of other batteries could result in injury or fire.
- ⚠ WARNING:** Keep battery (VP1086), when not in use, away from paper clips, coins, keys, nails, screws, or other small metal objects that could cause bridging of the contacts. A short circuit between the battery contact can cause burns or fire.
- ⚠ WARNING:** Never operate the installation tool without the mandrel collection bottle (VP1002) or cover cap (VP1321).
- ⚠ WARNING:** By-passing the safety switch is prohibited. Do not use if switch is defective or can no longer be turned on or off.
- ⚠ WARNING:** Do not use cover cap (VP1321) with non self releasing nose assemblies. Damage to tool will occur.
- ⚠ WARNING:** Ensure the mandrel collection bottle (VP1002) / cover cap (VP1321) are properly connected and used correctly.
- ⚠ WARNING:** Avoid inadvertent starting of the installation tool.
- ⚠ WARNING:** Having your finger on the actuator assy (VP1572) while carrying the installation tool can lead to accidents.
- ⚠ CAUTION:** Check that the hanger clip (VP1322) is securely fitted before using the tool. Ensure the clip is not stretched too far apart and loses its tension.
- ⚠ CAUTION:** Do not use beyond the design intent.
- ⚠ CAUTION:** Remove the battery (VP1086) before making adjustments to the tool, changing accessories, or putting tool away. This precautionary measure prevents any unintentional starting of the installation tool.

Universal Quick Charger (VP1087):

1. Connect the universal quick charger (VP1087) into a wall socket using the cable supplied.
2. Push the battery (VP1086) carefully and without force into the holder. Remove the battery (VP1086) the same way.
3. The universal quick charger (VP1087) charges the battery (VP1087) in 30 minutes; the battery is 90% charged after approximately 22 minutes. Observe the corresponding indicators on the universal quick charger (VP1087).
4. The optimum charging and discharging temperature for the Li-Ion cells is 77°F (25°C). No complete charging or discharging capacity can be reached above and below 77°F (25°C).
5. Use only the connecting cable supplied (with IEC power connector).
6. Use universal quick charger (VP1087) to charge only the batteries (or new ones) supplied with tool.
7. Charge only in a temperature range between 32°F - 104°F (0°C - 40°C).



Charging the Battery (VP1086):

Note: The battery (VP1086) is partially charged on delivery.

1. In order to ensure the full performance of the battery (VP1086), charge the battery (VP1086) completely before the first use. Observe the notes on the state of charge on the universal quick charger (VP1087).
2. The Li-Ion battery (VP1086) can be recharged at any time without shortening its service life.
3. Interruptions of the charging cycle does not damage the battery (VP1086).
4. The charger (VP1087) is equipped with a temperature monitoring device that permits charging only in the temperature range between 32°F - 104°F (0°C - 40°C).





Battery (VP1086):

1. Always make removing the battery (VP1086) from the installation tool your ***first*** step before making adjustments, changing parts or overhauling and installing the battery (VP1086) into the tool your ***last*** step before using to prevent accidental starting of the tool.
2. The battery (VP1086) has a latch on the front side. To insert or remove the battery, press the latch downwards and push the battery (VP1086) into the installation tool foot or pull it out.
3. Use the battery (VP1086) in the installation tool only in the specified temperature range 23°F - 113°F (-5°C - 45°C).
4. Charge the battery (VP1086) only in a temperature range between 32°F - 104°F (0°C - 40°C).
5. Use only an approved charger.
6. Never short-circuit the battery (VP1086).
7. If the battery (VP1086) shows signs of visible damage, do not use it any longer and dispose of it in a proper manner.
8. Keep the battery (VP1086) away from moisture and liquids.

Preparing the Installation Tool (GB107):

1. Attach the mandrel collection bottle (VP1002) by turning to the right.
Note: Tool will not function without mandrel collection bottle (VP1002) or cover cap (VP1321) attached. (See safety switch below).
2. Push the battery (VP1086) into the foot of the installation tool from the front and ensure it is properly engaged.

Safety Switch:

1. This installation tool is equipped with a safety switch in the rear of installation tool and thus conforms to the Machinery Directive. This prevents the installation tool from being used without the mandrel collection bottle (VP1002) or cover cap (VP1321).
2. Never bypass the safety switch.
3. Never operate the tool without the mandrel collection bottle (VP1002) or cover cap (VP1321).
4. If you have to work in confined spaces, the cover cap (VP1321) can be used instead of the mandrel collection bottle (VP1002).
5. When working with the cover cap (VP1321), hold the installation tool with the anvil insert facing downwards after each set fastener to ensure that the sheared mandrel drops out of the tool to the front.
6. Do not use cover cap (VP1321) with non-self releasing nose assemblies. This would result in damage to the installation tool.



Images may not reflect actual tool



Additional Actuator Assy (VP1572) functions:

1. Auto and Manual mode:
 - a. In Manual mode, hold the actuator assy (VP1572), depressing during setting of the fastener until the mandrel is sheared off.
 - b. In Auto mode, you only have to press the actuator assy (VP1572) briefly and the installation tool controls the fastening process automatically.
2. To change from one mode to the other, hold the actuator assy (VP1572) pressed for ten seconds (until the white LED on the tool starts to flash (2 sec.) and release again. Press the actuator assy (VP1572) briefly and the tool moves to its starting position again.

Attaching the Belt Clip (VP1322):

Note: Always ensure belt clip (VP1322) is secure to the installation tool before using.

1. Attach the belt clip (VP1322) to the foot of the installation tool using the screw. A corresponding thread and slots are recessed in the foot of the housing on both sides of the installation tool.
2. Check at regular intervals that the belt clip (VP1322) is still securely attached. Otherwise, retighten the screw.



Battery (VP1086) Storage:

1. Protect the battery (VP1086) from moisture and liquids. Do not leave in car e.g. in the summer.
2. Store the battery (VP1086) only in optimum temperature range between -22°F (-30°C) and 77°F (25°C). The batteries can be stored as follows without recharging:

Storage period between 22°F (-30°C) and 77°F (25°C) = 1.5 years

Storage period between 22°F (-30°C) and 113°F (45°C) = 3 months

Storage period between 22°F (-30°C) and 140°F (60°C) = 1 month

3. A significantly shorter operating time after recharging indicates that the battery (VP1086) is worn out and needs to be replaced. Observe all local disposal procedures.

HOW TO USE THE GB107



- ⚠ WARNING:** Only qualified and trained operators should install, adjust or use the installation power tool for all fasteners.
- ⚠ WARNING:** Operator **MUST** read and understand all warnings and cautions.
- ⚠ WARNING:** It is required that eye protection, hearing protection and safety boots be worn at all times while handling this equipment.
- ⚠ WARNING:** The users or the user's employer should assess specific risks that could be present before each use based on their application.
 - *Be sure there is adequate clearance for tool and operator's hands before proceeding. Keep fingers clear of any moving parts. Keep fingers clear from fasteners and installed materials. Severe personal injury may result.*
 - *Ensure that there are no electrical cables, gas pipes, etc., which can cause a hazard if damaged by the tool.*
- ⚠ WARNING:** Do not pull fastener in the air. Personal injury from fastener ejecting may occur.
- ⚠ WARNING:** Do not use as a hammer. If improperly used or damaged, liquid can escape from the battery causing skin irritations or burns. Wash with water or seek medical attention immediately if liquid gets into eyes or burns occur.
- ⚠ WARNING:** Do not use in explosive atmosphere.
- ⚠ WARNING:** Charge the batteries only in chargers recommended by the manufacturer. Risk of fire or explosion if batteries used on non manufacturer chargers.
- ⚠ WARNING:** Use only the specified batteries in the tool. The use of other batteries could result in injury or fire.
- ⚠ WARNING:** Keep battery (VP1086), when not in use, away from paper clips, coins, keys, nails, screws, or other small metal objects that could cause bridging of the contacts. A short circuit between the battery contact can cause burns or fire.
- ⚠ WARNING:** Never operate the installation tool without the mandrel collection bottle (VP1002) or cover cap (VP1321).
- ⚠ WARNING:** By-passing the safety switch is prohibited. Do not use if switch is defective or can no longer be turned on or off.
- ⚠ WARNING:** Do not use cover cap (VP1321) with non self releasing nose assemblies. Damage to tool will occur.
- ⚠ WARNING:** Ensure the mandrel collection bottle (VP1002) / cover cap (VP1321) are properly connected and used correctly.
- ⚠ WARNING:** Avoid inadvertent starting of the installation tool.
- ⚠ WARNING:** Having your finger on the actuator assy (VP1572) while carrying the installation tool can lead to accidents.
- ⚠ CAUTION:** Check that the hanger clip (VP1322) is securely fitted before using the tool. Ensure the clip is not stretched too far apart and loses its tension.
- ⚠ CAUTION:** Do not use beyond the design intent.
- ⚠ CAUTION:** Remove the battery (VP1086) before making adjustments to the tool, changing accessories, or putting tool away. This precautionary measure prevents any unintentional starting of the installation tool.

Working with the Installation tool (GB107):

1. Insert the mandrel of the fastener into the nose assembly.
 - Note:** Tool will not function without the mandrel collection bottle (VP1002) or cover cap (VP1321) attached.
2. Now insert the fastener into the parts to be fastened. For a good fastening result, ensure that the parts and head of the fastener are resting on one another without a gap.
3. Press the actuator assy (VP1572) until the mandrel is sheared.
4. Hold the installation tool so that the mandrel collection bottle (VP1002) is facing downwards to ensure that the sheared mandrel drops into the mandrel collection bottle (VP1002).
5. When working with the cover cap (VP1321), hold the installation tool with the nose assy facing downwards after each set fastener to ensure that the sheared mandrel drops out of the installation tool to the front. **DO NOT** use cover cap (VP1321) with non self releasing nose assemblies. This would result in damage to the tool.

Blind Fasteners

1. Insert fastener into workpiece.
2. Insert fastener into nose assembly.
3. Press actuator to start cycle.
4. Release actuator as soon as fastener breaks.
5. Repeat steps 1 - 4.

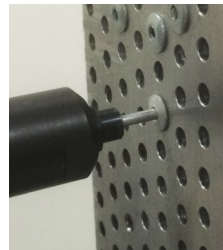

Images may not reflect actual tool or fastener

DAILY MAINTENANCE



- ⚠ WARNING:** Do not use tool if switch is defective.
- ⚠ WARNING:** Keep installation tool out of the reach of children when not in use.
- ⚠ WARNING:** Maintenance personnel **MUST** read and understand all warnings and cautions.
- ⚠ WARNING:** Disconnect battery before performing maintenance, cleaning or when replacing worn or damaged components. Severe personal injury may occur if power source is not disconnected.
- ⚠ WARNING:** Read SDS documents for all applicable materials.
- ⚠ WARNING:** Installation tool must be repaired only by qualified specialist personnel and only with original spare parts. This will ensure the safety of the installation tool is maintained.

The performance of any tool depends upon good maintenance practices. Following these minimal requirements daily will extend the life of your tool.

- * An installation tool that can no longer be switched on or off is dangerous and must be repaired.
- * Maintain installation tools with care. Check that moving parts function correctly and do not jam.
- * Check that parts are not broken or damaged in such a way that the function of the installation tool is impaired.
- * Have damaged parts repaired before using the tool. Accidents are caused by poorly serviced tools.
- * Use installation tool, accessories, attachments, etc. only as described in these instructions.
- * Give consideration to the working conditions and the work to be carried out. The use of tools for other than intended applications can lead to dangerous situations.
- * Visual inspection of the installation tool should be done daily by the maintenance personnel.
- * Battery charge state should be done daily by the maintenance personnel.
- * Cleaning and lubricating the clamping jaws should be done between 1,000 and 10,000 fasteners depending on the fastener type, by the maintenance personnel.
- * Changing the jaws should be done by the maintenance personnel when the fastener can no longer be set in one stroke.
- * Changing the anvil insert should be done by the maintenance personnel every 25,000 to 50,000 fasteners.
- * Full inspection should be done every 300,000 fasteners or once a year by qualified trained maintenance personnel or by Gage Bilt.

Battery Disposal:

1. Do not throw the battery (VP1086) into the domestic waste, fire or water.
2. Batteries/ rechargeable batteries are collected and recycled or disposed of in an eco-friendly manner.

For EU countries only:

1. In accordance with Directive 91/157/EEC, defective old batteries must be recycled. Batteries that can no longer be used can be returned to your dealer.

Disposal of Installation Tool and Quick Charger:

1. Installation tools, chargers, accessories and packaging's should be recycled in an eco-friendly manner.
2. Do not throw tools into the domestic waste.

For EU countries only:

1. In accordance with European Directive 2002/96/EC on Waste Electrical and Electronic Equipment and implementation in national law, Installation tools must be collected separately and recycled in an eco-friendly manner at the end of the useful life.

CLEANING AND LUBRICATING THE CLAMPING JAWS

Depending on the mandrel material, shear force and surface finish, the clamping jaws have to be cleaned and replaced at regular intervals.

Clean nose assembly daily or as often as needed.

1. Loosen and remove the anvil assembly using a combination wrench.
2. Loosen and remove collet from adapter using two wrenches and remove the 3 piece jaw set from the collet.
3. Clean jaws and inspect for wear. Replace if necessary. Use a sharp "pick" to remove embedded particles from grooves of jaws.
4. Clean the inside and outside of collet. Grease the inside lightly with graphite grease using a brush.
5. Place jaw set into the collet.
6. Install collet with jaws back onto tool and reassemble nose assembly per data sheet instructions.

TROUBLESHOOTING



Providing all maintenance conditions have been met, follow this systematic approach to diagnosis.

1. **INSTALLTION TOOL STOPS AND A RED LED COMES ON.**
 - a) Fasteners are used beyond the specified performance capability of the tool. Wait until the red LED goes out and press the actuator assy (VP1572) briefly again. The tool then moves to its starting positions.
2. **THE INSTALLATION TOOL COMPLETES THE CYCLE THEN STOPS AND YELLOW LED COMES ON.**
 - a) The battery (VP1086) is dead. The tool is guarded by a protection circuit. Replace the battery with a fully charged one. The yellow LED turns off and you can continue working.
3. **THE INSTALLATION TOOL DOESN'T WORK WITH AND THE YELLOW & RED LED'S COME ON.**
 - a) Check mandrel collection bottle (VP1002) and empty if needed. Ensure mandrel collection bottle (VP1002) or cover cap (VP1321) is securely mounted and fully engaged in the rear of the installation tool, activating the safety switch (See page 9). The yellow and red LED'S turn off and you can continue working.
4. **THE INSTALLATION TOOL DOESN'T WORK AND THE GREEN, YELLOW AND RED LED'S COME ON.**
 - a) Installation tool is in need of service. Please contact Gage Bilt.



Image may not reflect actual tool

GB107 PARTS LIST

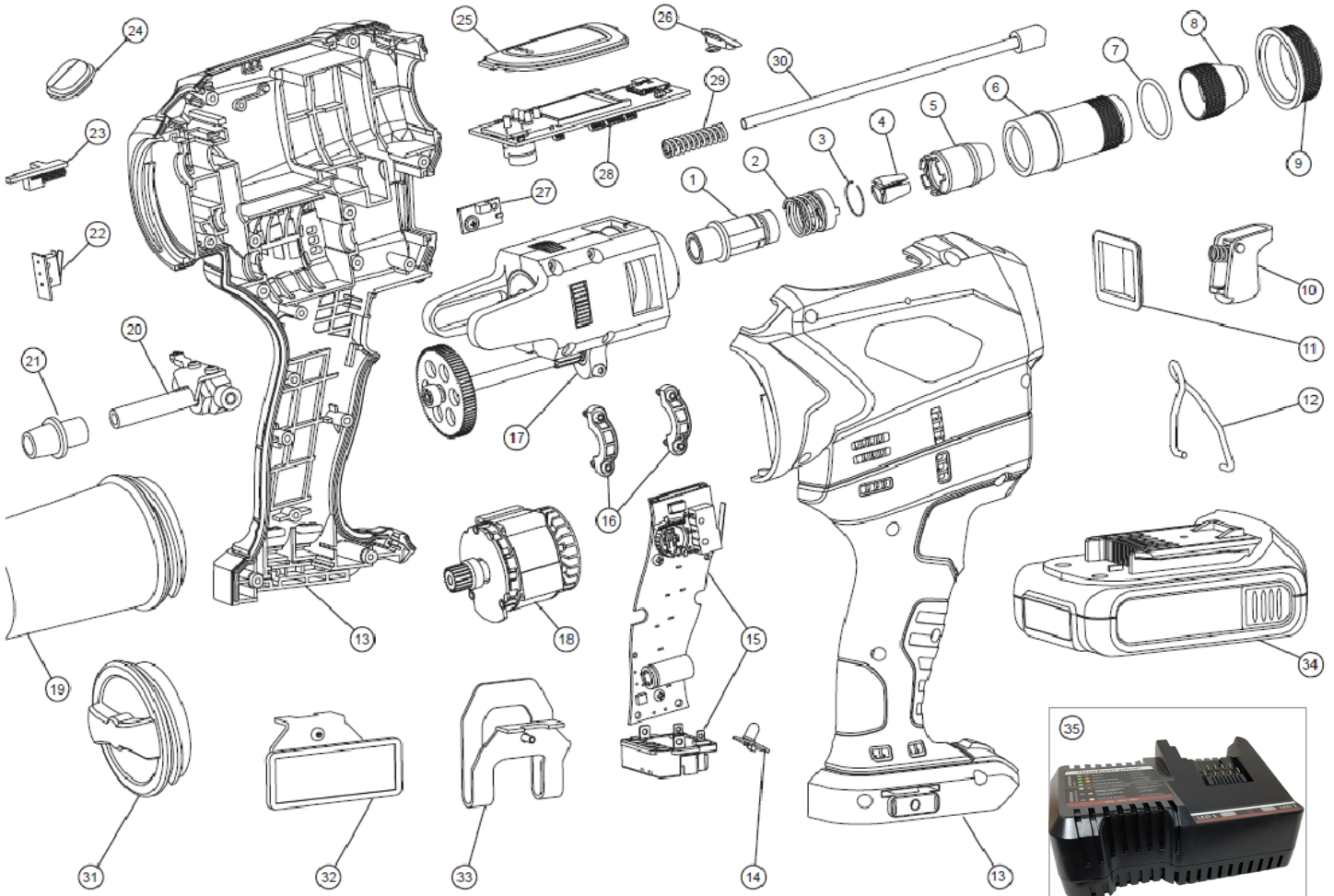

REF NO.	PART NO.	DESCRIPTION	QTY.	REF NO.	PART NO.	DESCRIPTION	QTY.
1	VP1561	SPACER (ADAPTER)	1	18b	VP1580	SCREW FOR MOTOR	1
2	VP1562	QUICK RELEASE & SPRING	1	19a*	VP1324	MANDREL CONTAINER-SHORT S (5.5CM)	1
3	VP1563	QUICK RELEASED C-RING	1	19b	VP1002	MANDREL CONTAINER L (8.0CM)	1
4	VP1031	CLAMPING JAW SET (1 SET=3 PCS.)	1	19c*	VP1356	MANDREL CONTAINER L+ (8.0CM)	1
5	VP1564	CLAMPING SLEEVE	1	19d*	VP1425	MANDREL CONTAINER XL+ (11.5CM)	1
5a	VP1208	O'RING	1	20	VP1581	TORQUE ARM COMPLETE	1
6	VP1565	FRONT SLEEVE (INCL. #7 O'RING)	1	20a	VP1582	MAGNET HOLDER	1
7	VP1566	O'RING	1	20b	VP1583	SCREW FOR MAGNET HOLDER	1
8a	VP1567	STANDARD NOSE PIECE 2.4 MM (3/32)	1	21	VP1584	PLASTIC TUBE	1
8b	VP1568	STANDARD NOSE PIECE 3.2 MM (1/8)	1	22	VP1585	MANDREL SAFETY-SWITCH + CABLE	1
8c	VP1569	STANDARD NOSE PIECE 4.0 MM (5/32)	1	23	VP1586	MAND. SAFETY SWITCH LEVER&SPRING	1
8d	VP1570	STANDARD NOSE PIECE 5.0 MM (3/16)	1	24	VP1545	COVER TOP LED	1
9	VP1571	UNION RING	1	25	VP1479	DISPLAY PROTECTION	1
10	VP1572	TRIGGER AND PRESSURE SPRING	1	26	VP1587	SD CARD SOFT COVER	1
11	VP1535	COVER SCANNER	1	27	VP1588	HALL SENSOR & ELECTRONIC	1
12	VP1470	HANGER	1	28	VP1589	SCREW FOR ELECTRONICS	1
13	VP1573	HOUSING (LEFT & RIGHT)	1	28a	VP1590	CONTROL ELECTRONICS	1
13a	VP1011	HOUSING SCREWS (1 SET =10 PCS)	1	29	VP1591	SPRING	1
14	VP1574	LED	1	30	VP1592	MANDREL DISCHARGE TUBE	1
15	VP1575	ELECTRONIC ASSEMBLY COMPLETE	1	31	VP1321	COVER CAP	1
16	VP1007	MOTOR HOLDER SCREWS (1 SET=4 PCS)	1	32*	VP1323	NAME PLATE WITH SCREW	1
16a	VP1576	MOTOR HOLDER	1	33	VP1322	BELT CLIP WITH SCREW	1
17	VP1577	GEARBOX COMPLETE	1	34	VP1086	li-ion RivdomPLUS battery 20V/2.0Ah	1
17a	VP1011	SCREWS FOR MOTOR HOLDER (1 SET=10 PCS)	1	34a*	VP1357	li-ion RivdomPLUS battery 20V/4.0Ah	1
18	VP1578	MOTOR 740 COMPLETE	1	35	VP1087	UNIVERSAL QUICK CHARGER 110V	1
18a	VP1579	SCREW FOR MOTOR	1				

* Sold Separately

GB107 SHOWN ABOVE

GB107 SERIES	
GB107	Includes (1) VP1086 (2Ah Battery)
GB107/2	Includes (2) VP1086 (2Ah Batteries)

- 19a. Mandrel Container-Short S (VP1324)
- 19c. Mandrel Container L+ (VP1356)

- 19b. Mandrel Container L (VP1002)
- 19d. Mandrel Container XL+ (VP1425)





This page intentionally left blank

Alternate Tools

(Sold Separately)



GB101

Blind rivets 3/32" (2.4 mm) thru 5/32" (4.0 mm) diameter.



GB101S

Blind rivets 3/32" (2.4 mm) thru 5/32" (4.0 mm) diameter.
Process Monitoring.



GB101A

Pulls a variety of small diameter aerospace fasteners.
Contact Gage Bilt for nose assembly & fastener options.



GB106

Blind rivets 3/32" (2.4 mm) thru 3/16" (4.8 mm) diameter.



GB107A

Blind rivets 3/32" (2.4 mm) thru 3/16" (4.8 mm) diameter.
Contact Gage Bilt for nose assembly options.



GB108

Blind rivets 3/32" (2.4 mm) thru 1/4" (6.3 mm) diameter.



GB108A

Blind rivets 3/32" (2.4 mm) thru 1/4" (6.3 mm) diameter.
Contact Gage Bilt for nose assembly options.



GB110A

Blind rivets 3/32" (2.4 mm) thru 1/4" (6.3 mm) & specific 5/16" (7.9 mm) diameters.
Lockbolts 5/32" (3.9 mm) thru 1/4" (6.3 mm).
Contact Gage Bilt for nose assembly options.



GB110AOS

Blind rivets 1/8" (3.2 mm) thru 1/4" (6.3 mm)
Lockbolts 5/32" (3.9 mm) thru 1/4" (6.3 mm).
Contact Gage Bilt for nose assembly options.



GB116RN(I)

Rivet nuts M4-M10, M3/M12 Optional,
Rivet studs M4-M8
Process Monitoring



GB128

1/4" (6.3 mm) thru 5/16" (7.9 mm) diameter seal plug.