

# GB2581 GB2581A

## HYDRAULIC INSTALLATION TOOL

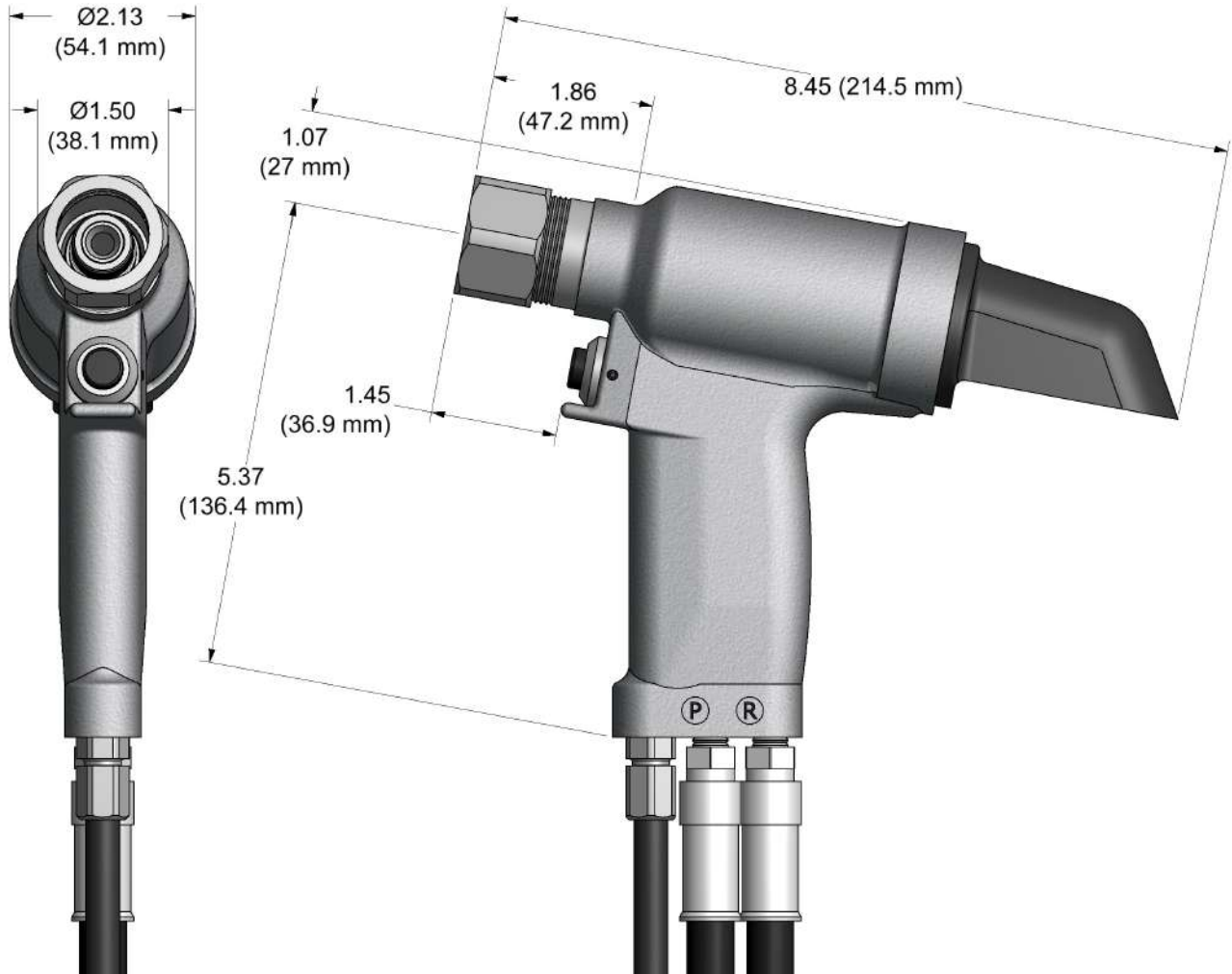

### DESCRIPTION

The GB2581 & GB2581A is a hydraulic installation tool designed specifically for the efficient installation of a wide range of blind, lockbolt and Magna-Grip® fasteners thru 3/8" diameter. It weighs 6.6 lbs. (2.99 kg) and can be operated in any position with one hand. It has a 1.000" (25.4 mm) rivet setting stroke and a rated pull load of 10,700 lbs. (47.59 kN) @ 7,400 psi. (510.2 bar).

The GB2581 installation tool operates on hydraulic pressure developed by the GB940 power unit set at 7,400 psi. (510.2 bar) maximum PULL pressure and 3,200 psi (220.6 bar) maximum RETURN pressure. The tool comes equipped with 12 ft. hoses and electric cord kit complete with quick disconnects.

The GB2581(A) installation tool operates on hydraulic pressure developed by the GB910 Power unit set at 7,400 psi (510.2 bar) maximum PULL pressure and 3,200 psi (220.6 bar) maximum RETURN pressure. The tool comes equipped with 12 feet of hydraulic hoses, couplings, air actuator and tubing.

**NOSE ASSEMBLIES ARE NOT FURNISHED WITH THE RIVETER AND MUST BE ORDERED SEPARATELY.**

**GAGE BILT**  
 **MADE in USA**

**ADVANCE**  
COMPONENTS





# GB2581/GB2581A NOSE ASSEMBLY SELECTION CHART



## ACCESSORIES (SOLD SEPARATELY)

## NOSE ASSEMBLIES (SOLD SEPARATELY)

**CATCHER BAG**  
#756610



### STRAIGHT

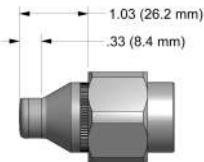

### OFFSET

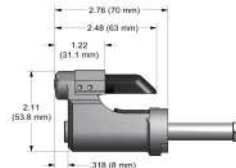

FASTENER	DIA.	STRAIGHT		*OFFSET	
ASP® 2 ASP & ASP PF ASP FF & ASP F ASP-LC	13/64 17/64 21/64	ASP06-745B-23 ASP08-745B-23 ASP10-755-23	ASP06-745B-48 ASP08-745B-48 ASP10-755-48	ASP06-204D-27OS ASP08-204D-27OS ASP10-204D-27OS	ASP06-204D-37OS ASP08-204D-37OS ASP10-204D-37OS
BOM® BLIND OVERSIZE MANDREL	1/4 5/16 3/8	BOM08-755-23 BOM10-756-26 **BOM12-756A-26			
COMMERCIAL LOCKBOLTS C6L® AVDELOK®	3/16 1/4 5/16 3/8	NAS06-745B-12 NAS06-755-23 NAS08-745B-12 NAS08-745B-12 LB10-745C-26 LB12-756-26	NAS06-755-48 NAS08-755-48 NAS10-756-26 NAS12-756-48	NAS06-204C-25OS NAS06-204C-34OS NAS08-204C-25OS NAS08-205A-31 NAS10-205D-31 NAS12-205A-31	NAS06-204C-30OS NAS08-204D-30OS NAS08-204C-34OS
CONTAINER BOLT	3/8	HT12-756-23			
FLOOR BOLT	5/16	FT10-353A-28			
LGP® LIGHTWEIGHT GROOVE PORPORTION LOCKBOLTS	5/32	LGP05-2581-12 LGP05-2581-48	LGP05-2581-23	LGP05-204C-25OS LGP05-204C-34OS	LGP05-204C-30OS
	3/16	LGP06-2581-12 LGP06-2581-48	LGP06-2581-23	LGP06-204C-25OS LGP06-204C-34OS	LGP06-204C-30OS
	7/32	LGP07-745B-12 LGP07-755-48	LGP07-755-23	LGP07-204C-25OS LGP07-204C-34OS	LGP07-204C-30OS
	1/4	LGP08-2581-12 LGP08-2581-48	LGP08-2581-23	LGP08-204C-25OS LGP08-204C-34OS	LGP08-204D-30OS LGP08-205A-31
	5/16	LGP10-2581-12 LGP10-2581-48	LGP10-2581-23	LGP08-204C-25OS LGP08-204C-34OS LGP10-205D-31	
3/8	LGP12-745B-12 LGP12-756-48	LGP12-756-26	LGP12-205A-31		
LOCKBOLT NAS SHEAR PULL TYPE NAS TENSION PULL TYPE & GROOVE PORPORTION NASS = NAS SHEAR NAST = NAS TENSION	5/32	NASS05-755-12 NASS05-755-23 NASS05-755-48	NAST05-2581-12 NAST05-755-23 NAST05-755-48	NASS05-204C-25OS NASS05-204C-30OS NASS05-204C-34OS	NAST05-204C-20OS NAST05-204C-30OS NAST05-204C-34OS
	3/16	NAS06-745B-12 NAS06-755-48	NAS06-755-23	NAS06-204C-25OS NAS06-204C-34OS	NAS06-204C-30OS
	1/4	NAS08-745B-12 NAS08-755-48	NAS08-755-23	NAS08-204C-25 NAS08-204C-34	NAS08-204D-30 NAS08-205A-31
	5/16	NAS10-745B-12 NAS10-756-48	NAS10-756-26	NAS10-205D-31	
	3/8	NAS12-745B-12 NAS12-756-48	NAS12-756-26	NAS12-205A-31	
MULTI-GRIP LOCKBOLT	3/16	MG06-745-48			
	1/4	MG08-745-48			
	5/16	MG10-756-28			
	3/8	MG12-756-28			
MULTI-GRIP STRUCTURAL BLIND RIVET	3/8	MGL12-353C-28			
OVERSIZE STRUCTURAL RIVET	1/4	OS08-745-48			
	5/16	OS10-756-26	OS10-756-48		
	3/8	OS12-756A-26	OS12-756A-48		
BLIND BOLT (SINGLE ACTION) WITH OR W/OUT DRIVE WASHER	5/32	SB05-745C-23	SB05-745C-48	SB05-204D-27OS	SB05-204D-37OS
	3/16	SB06-745B-23	SB06-745B-48	SB06-204D-27OS	SB06-204D-37OS
	1/4	SB08-755-23	SB08-755-48	SB08-204D-27OS	SB08-204D-37OS
	5/16	SB10-756-28	SB10-756-48	SB08-205A-35 SB10-205A-35	
3/8	SB12-756-28	SB12-756-48	SB12-205A-35		
BLIND BOLT (SINGLE ACTION) WITH DRIVE WASHER	5/32	UBB05-745C-23	UBB05-745C-48	UBB05-204D-27OS	UBB05-204D-37OS
	3/16	UBB06-745B-23	UBB06-745B-48	UBB06-204D-27OS	UBB06-204D-37OS
	1/4	UBB08-755-23	UBB08-755-48	UBB08-204D-27OS	UBB08-204D-37OS
	5/16	UBB10-756-28	UBB10-756-48	UBB08-205A-35 UBB10-205A-35	
	3/8	UBB12-756-28	UBB12-756-48	UBB12-205A-35	

**NAS LOCKBOLTS AND BLIND FASTENERS**  
#GB105093 (EQUIVALENT TO #105093)



**GAGE BILT ALSO SUPPLIES PIN & COLLAR SWAGE INSPECTION GAGES TO CERTIFY CORRECT SWAGE INSTALLATION.**



ASP®, BOM®, C6L®, AND LGP® ARE REGISTERED TRADEMARKS OF ALCOA INC. AVDELOK® IS A REGISTERED TRADEMARK OF AVDEL UK LIMITED.

### GAGE BILT CERTIFIES THE GB2581 WILL INSTALL THE ABOVE FASTENERS

\*ALL OFFSET 204 SERIES NOSES REQUIRE 353204 ADAPTER WITH 258152 STROKE LIMITER AND 258157 RELIEF VALVE.

\*ALL OFFSET 205 SERIES NOSES REQUIRE 353205 ADAPTER WITH 258153 STROKE LIMITER AND 258156 RELIEF VALVE.

\*\* Repair Only

NOTE: THE LAST 2 DIGITS OF THE NOSE ASSEMBLY REPRESENTS THE LENGTH THE NOSE EXTENDS FROM THE TOOL I.E. -20 = 2.0 INCHES