

GB2620 GB2620A

HYDRAULIC INSTALLATION TOOL

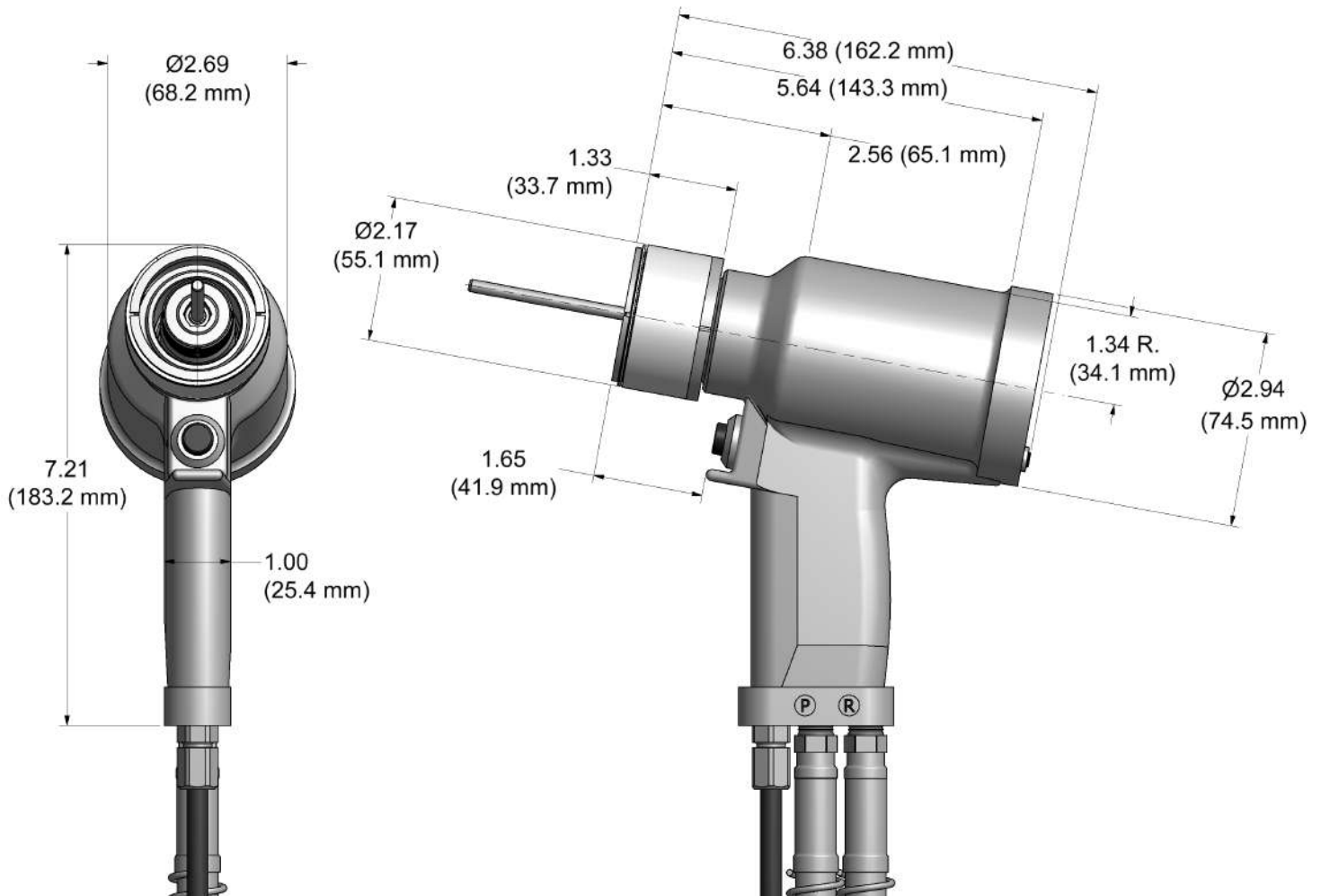

DESCRIPTION

The GB2620 and the GB2620A are hydraulic installation tools designed specifically for the efficient installation of 1/2" diameter lock-bolts. It weighs just over 9lbs. 14 oz. (4.5 kg). and can be operated in any position. It has a 1.437" (36.5mm) rivet stroke and a rated pull load of 17,745 lbs. (78.9kN) @ 6,500 psi. (448.2 bar).

The GB2620 (Electric actuated) installation tool operates on hydraulic pressure developed by the GB940 Powerunit set at 7,400 psi (510.2 bar) maximum PULL pressure and 3,200 psi. (220.6 bar) maximum RETURN pressure. The tool comes equipped with 2 feet (.61 m) of hydraulic hoses and couplings, electric switch and cord.

The GB2620A (Air actuated) installation tool operates on hydraulic pressure developed by the GB910 & GB912 Powerunits set at 7,400 psi (510.2 bar) maximum PULL pressure and 3,200 psi. (220.6 bar) maximum RETURN pressure. The tool comes equipped with 2 feet (.61 m) of hydraulic hoses, swivels and couplings, air actuator and tube.

**ALL GAGE BILT HYDRAULIC INSTALLATION TOOLS ARE COMPATIBLE WITH HUCK® POWERUNITS.
NOSE ASSEMBLIES ARE NOT FURNISHED WITH THESE TOOLS AND MUST BE ORDERED SEPARATELY.**

GAGE BILT
 **MADE in USA**

ADVANCE
COMPONENTS





ACCESSORIES



GB2620 SELECTION CHART



FASTENER	DIA.	NOSE ASSEMBLY
LOCKBOLT HIGH TENSILE PULL TYPE C50L® LD AVDELOK®	1/2"	16-2620-41
BOM® AVBOLT®	1/2"	BOM16-2620A-41
HP8	1/2"	CONTACT GAGE BILT FOR YOUR REQUIREMENTS
HP10.9	12mm	CONTACT GAGE BILT FOR YOUR REQUIREMENTS

C50L® AND BOM® ARE REGISTERED TRADEMARKS OF ARCONIC INC. AVDELOK® AND AVBOLT® ARE REGISTERED TRADEMARKS OF AVDEL UK LIMITED.

GAGE BILT CERTIFIES THE GB2620 WILL INSTALL THE ABOVE FASTENERS

NOTE: THE LAST 2 DIGITS OF THE NOSE ASSEMBLY REPRESENTS THE LENGTH THE NOSE ASSEMBLY EXTENDS FROM THE TOOL. (I.e. -41 = 4.1 inches) REV. 9/17

WARRANTY

Seller warrants that all goods covered by this catalog will conform to applicable specifications and will replace or repair, EXW our plant, any goods providing defective from faulty workmanship, or material, for 1 year from date of shipment.

Said warranty to remain in effect if, and only if, such goods are used in accordance with all instructions as to maintenance, operation and use, set forth in manuals and instruction sheets furnished by seller.

Sellers obligation under this warranty shall be limited to the repair or rework of the goods supplied or replacement thereof, at Seller's option, and in no case is to exceed the invoice value of said goods. Under no circumstances will the seller be liable for incidental or consequential damages or for damages incurred by the buyer or subsequent user in repairing or replacing defective goods or if the goods covered by this warranty are reworked or subjected to any type of additional processing.

This warranty is void if Seller is not notified in writing of any rejections or defects within 1 year after the receipt of the material by the customer.

THIS WARRANTY IS MADE IN LIEU OF ALL OTHER WARRANTIES EXPRESSED OR IMPLIED, INCLUDING MERCHANTABILITY.

ADVANCE
COMPONENTS

