

GB3585

GB3585A

HYDRAULIC
INSTALLATION TOOL

GAGE BILT

RIVET & LOCKBOLT TOOLS

MASTER DISTRIBUTOR



ADVANCE
COMPONENTS

advancecomponents.com 972.446.5500

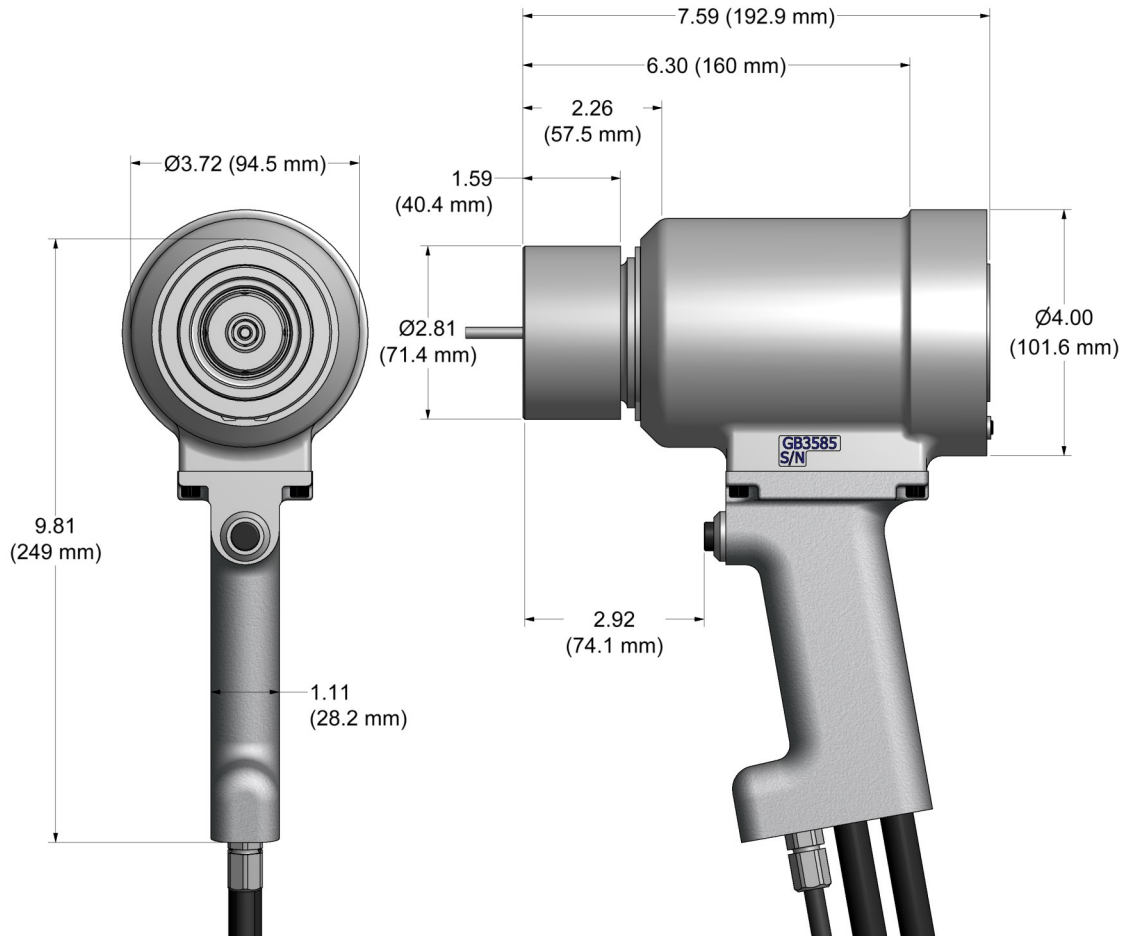

The **GB3585** and the **GB3585A** are hydraulic installation tools designed specifically for the efficient installation of 1/2" - 3/4" diameter pintail and pintail-less style lockbolts. It weighs just over 19 lbs. (18.6 kg), and can be operated in any position. It has a 1.810" (46 mm) fastener stroke and a rated pull load of 45,668 lbs. (203 kN) @ 7,400 psi. (510 bar).

The **GB3585** electrically actuated installation tool operates on hydraulic pressure developed by the GB940 Power Unit set at 7,400 psi (510 bar) maximum PULL pressure and 2,200 psi. (152 bar) maximum RETURN pressure. The tool comes equipped with 2 feet (.61 m) of hydraulic hoses and couplings, electric switch and cord.

The **GB3585A** air actuated installation tool operates on hydraulic pressure developed by the GB910 Power Unit set at 7,400 psi (510 bar) maximum PULL pressure and 2,200 psi. (152 bar) maximum RETURN pressure. The tool comes equipped with 2 feet (.61 m) of hydraulic hoses, swivels and couplings, air actuator and tube.

**ALL GAGE BILT HYDRAULIC INSTALLATION TOOLS ARE COMPATIBLE WITH EQUIVALENT POWERUNITS.
NOSE ASSEMBLIES ARE NOT FURNISHED WITH THESE TOOLS AND MUST BE ORDERED SEPARATELY.**



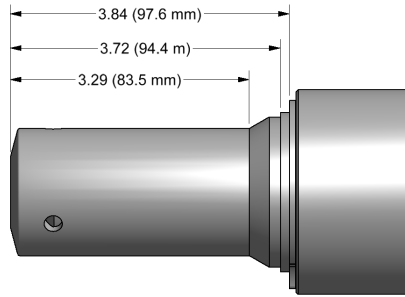

FASTENER	DIA.	NOSE ASSEMBLY
LOCKBOLT HIGH TENSILE PULL TYPE C50L® LD AVDELOK®	1/2" 5/8" 3/4"	16-7624-40 20-585-41 24-585-46
BOM® AVBOLT®	1/2" 5/8" 3/4"	BOM16-7624A-40 BOM20-585-41 BOM24-585-46
HP8	5/8" 3/4"	CONTACT GAGE BILT FOR YOUR REQUIREMENTS
HP10.9	16mm 20mm	CONTACT GAGE BILT FOR YOUR REQUIREMENTS

C50L® AND BOM® ARE REGISTERED TRADEMARKS OF ARCONIC INC. AVDELOK® AND AVBOLT® ARE REGISTERED TRADEMARKS OF AVDEL UK LIMITED

GAGE BILT CERTIFIES THE GB3585 WILL INSTALL THE ABOVE FASTENERS

See gagebilt.com/nose_assemblies.php for nose assembly information (data sheets)

NOTE: THE LAST 2 DIGITS OF THE NOSE ASSEMBLY REPRESENTS THE LENGTH THE NOSE ASSEMBLY EXTENDS FROM THE TOOL. (I.e. -40 = 4.0 inches)

5/19

WARRANTY

Seller warrants that all goods covered by this catalog will conform to applicable specifications and will replace or repair, EXW our plant, any goods providing defective from faulty workmanship, or material, for 1 year from date of shipment.

Said warranty to remain in effect if, and only if, such goods are used in accordance with all instructions as to maintenance, operation and use, set forth in manuals and instruction sheets furnished by seller.

Sellers obligation under this warranty shall be limited to the repair or rework of the goods supplied or replacement thereof, at Seller's option, and in no case is to exceed the invoice value of said goods. Under no circumstances will the seller be liable for incidental or consequential damages or for damages incurred by the buyer or subsequent user in repairing or replacing defective goods or if the goods covered by this warranty are reworked or subjected to any type of additional processing.

This warranty is void if Seller is not notified in writing of any rejections or defects within 1 year after the receipt of the material by the customer.

THIS WARRANTY IS MADE IN LIEU OF ALL OTHER WARRANTIES EXPRESSED OR IMPLIED, INCLUDING MERCHANTABILITY.