

GB7624 GB7624A

HYDRAULIC INSTALLATION TOOL

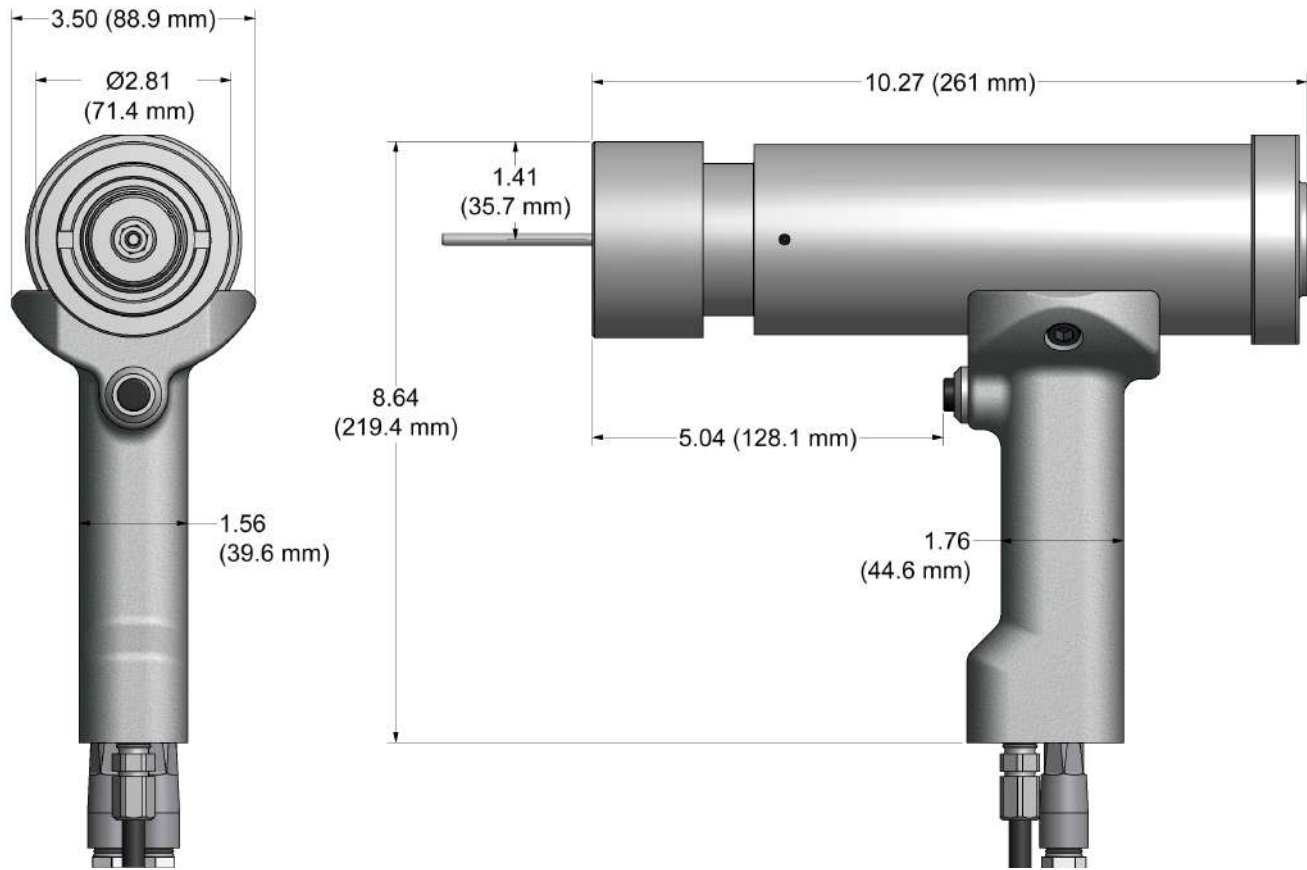

DESCRIPTION

The GB7624 & GB7624A are hydraulic installation tools capable of installing 5/8" and 3/4" standard lockbolts. They weigh 15 lbs (6.8 kg) and can be operated in any position with one hand. They have a 1.970" (50.0 mm) rivet setting stroke and a rated pull load of 40,000 lbs. (177.9 kN).

The GB7624 installation tool is designed to operate at pressures up to 10,000 psi (689.5 bar) on hydraulic pressure developed by the GB940 Powerunit. Normal operating pressure is set at 10,000 psi (689.5 bar) PULL pressure and 6,000 psi (413.7 bar) RETURN pressure, enabling the tool to pull all the fasteners listed on the selection chart without adjusting pressures. Powerunit may be set to the pressures only needed to pull your specific fastener using pressure setting gauge (942280) and setting pressures to amounts shown on the selection chart. The tool comes equipped with 24" hoses and electric cord kit complete with quick disconnects.

The GB7624A installation tool is designed to operate at pressures up to 10,000 psi (689.5 bar) on hydraulic pressure developed by the GB910 Powerunit. Normal operating pressure is set at 10,000 psi (689.5 bar) maximum PULL pressure and 6,000 psi (413.7 bar) maximum RETURN pressure, enabling the tool to pull all the fasteners listed on the selection chart without adjusting pressures. Powerunit may be set to the pressures only needed to pull your specific fastener using pressure setting gauge (942280) and setting pressures to amounts shown on the selection chart. The tools come equipped with the 24" hoses. Tool operates with an air actuator to pull rivet.

NOSE ASSEMBLIES ARE NOT FURNISHED WITH THE TOOL AND MUST BE ORDERED SEPARATELY.

GB7624 & GB7624A - SELECTION CHART

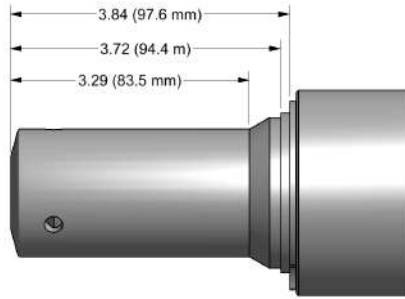

FASTENER	DIA.	NOSE ASSEMBLY	HYDRAULIC PRESSURE REQUIRED	
			PULL PSI	RETURN PSI
LOCKBOLT HIGH TENSILE PULL TYPE C50L®	1/2"	16-7624-40	5400-5700	2200-2400
	5/8"	20-585-41	6200-6400	3600-3800
	3/4"	24-585-46	8800-9200	5600-6000
BOM® BLIND OVERSIZE MANDREL	1/2"	BOM16-7624A-40	5400-5700	2200-2400
	5/8"	BOM20-585-41	6200-6400	3600-3800
	3/4"	BOM24-585-46	8800-9200	5600-6000
HP8	5/8" 3/4"	CONTACT GAGE BILT FOR YOUR REQUIREMENTS		
HP10.9	16mm	CONTACT GAGE BILT FOR YOUR REQUIREMENTS		

C50L® AND BOM® ARE REGISTERED TRADEMARKS OF ALCOA INC.

GAGE BILT CERTIFIES THE GB7624(A) WILL INSTALL THE ABOVE FASTENERS

NOTE: THE LAST 2 DIGITS OF THE NOSE ASSEMBLY REPRESENTS THE LENGTH THE NOSE ASSEMBLY EXTENDS FROM THE TOOL. (I.e. -25 = 2.5 inches)

Rev. 9/16

WARRANTY

Seller warrants that all goods covered by this catalog will conform to applicable specifications and will replace or repair, F.O.B. our plant, any goods providing defective from faulty workmanship, or material, for 6 months from date of shipment.

Said warranty to remain in effect if, and only if, such goods are used in accordance with all instructions as to maintenance, operation and use, set forth in manuals and instruction sheets furnished by seller.

Sellers obligation under this warranty shall be limited to the repair or rework of the goods supplied or replacement thereof, at Seller's option, and in no case is to exceed the invoice value of said goods. Under no circumstances will the seller be liable for incidental or consequential damages or for damages incurred by the buyer or subsequent user in repairing or replacing defective goods or if the goods covered by this warranty are reworked or subjected to any type of additional processing.

This warranty is void if Seller is not notified in writing of any rejections or defects within 6 months after the receipt of the material by the customer.

THIS WARRANTY IS MADE IN LIEU OF ALL OTHER WARRANTIES EXPRESSED OR IMPLIED, INCLUDING MERCHANTABILITY.

ADVANCE
COMPONENTS

