

# NOSE ASSEMBLY DATA SHEET

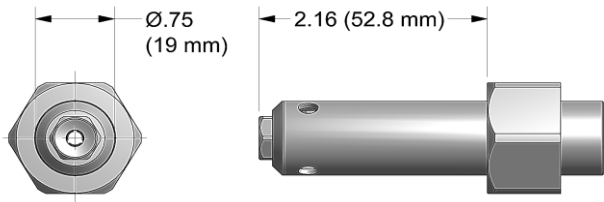

## ASSEMBLY:

**Note:** If nose assy is assembled as it is when purchased new, follow steps 5-7 to attach to tool.

1. Place extension-collet (8) on a flat work surface hex side up.
2. Place cap (7) on extension-collet (8). Note direction from exploded view.
3. Place spring (6) on top of cap (7). Insert follower (5) thru spring (6) and into cap (7) and extension-collet (8). Place jaw set (4) on top of follower (5).
4. Slide collet (3) over assembled parts and thread collet (3) to extension-collet (8). Snug tighten assembled parts using 9/16" wrench on collet (3) and 1/4" hex key in rear on extension-collet (8)
5. Thread assembled collet (3) and extension-collet (8) onto piston assy on tool and snug with 9/16" wrench on collet (3) and hex key into rear of piston of tool.
6. Slide anvil holder assy (2) over assembled collet (3) and extension-collet (8).
7. Slide retaining nut from tool (retaining nut stop not used in this nose assembly) over anvil holder assy (2) and tighten.

## DISASSEMBLY:

Reverse assembly instructions.

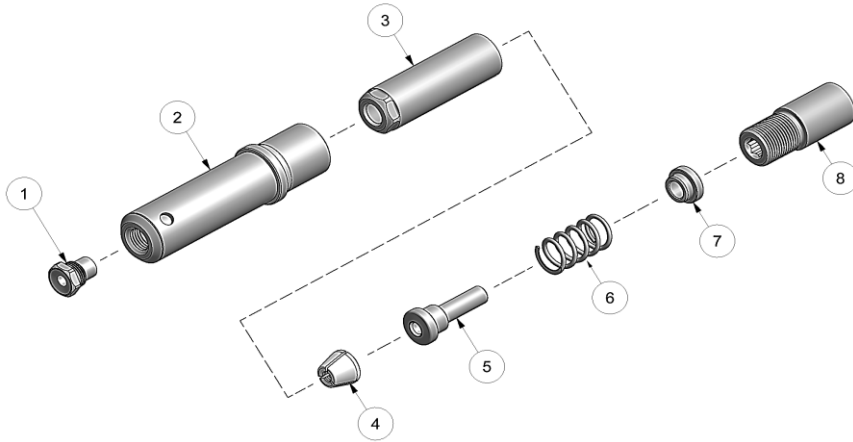

Fastener:	Dia.	Nose Assembly	Nose Tip		Jaw Set
			Protruding Head	Countersunk Head	
Multi-Grip Protruding Head	3/16"	MGL06-752A-21	10248	-----	30628
	1/4"	MGL08-752A-21	10205	-----	36801
Multi-Grip Countersunk Head	3/16"	MGLC06-752A-21	-----	10248-4	30628
	1/4"	MGLC08-752A-21	-----	10211-1	36801
Monobolt®	3/16"	MB06-752A-21	10210	10210	30628
	1/4"	MB08-752A-21	10213	10213	36801
Millimeter RV Plug	6mm	RVM6-752A-21	-----	10167-2	36801
	7mm	RVM7-752A-21	-----	10166-2	36801
	8mm	RVM8-752A-21	-----	10166-3	36801

Rev. 3/16

**GAGE BILT**  
MADE IN U.S.A.



advancecomponents.com 972-446-5500

Type:		Fastener:	Recommended Tool:
Self-Releasing		See Chart	GB713
			Alternate Tools: GB722 & GB2480(A)
Ref. No.	Qty.	Description	<b>XX-752A-21</b>
1	1	Nose Tip	See Chart
2	1	Anvil Holder Assy	10942-7
3	1	Collet	20845
4	1	Jaw Set	See Chart
5	1	Follower	40811
6	1	Spring	50421
7	1	Cap	40810
8	1	Extension-Collet	70823