

NOSE ASSEMBLY DATA SHEET

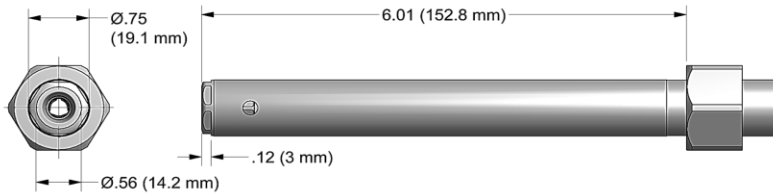

ASSEMBLY:

Notes:

- A. Apply Vibra-tite® p/n 405125 to all threads and allow it to set 20 minutes prior to assembly.
- B. Tighten extension-collet (6) to piston on tool 80-100 IN-LB torque.
- C. If nose assy is assembled as it is when purchased new, follow steps 3-5 to attach to tool.

1. Insert super grip jaw assy (5) into rear of collet (4). (Note direction in exploded view).
2. Thread collet (4) to extension-collet (6) using flats provided. Insert o'ring (7) into rear of extension-collet (6).
3. Thread assembly onto piston on tool and snug with 9/16" wrench on collet (4) and hex key (provided with tool) into rear of piston.
4. Slide anvil & holder assy (1) over collet (4).
5. Slide retaining nut on anvil and tighten to tool. (Note: retaining nut stop not used on this nose assy).

DISASSEMBLY:

Reverse assembly instructions.

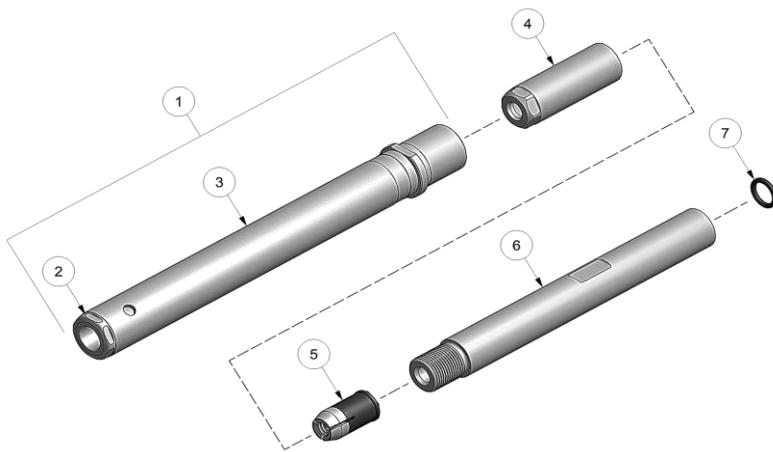

5/07 Rev. 10/18

GAGE BILT
MADE in USA

44766 Centre Court Clinton Twp. MI 48038 USA
Ph: +1 (586) 226-1500 Fax: +1 (586) 226-1505
solutions@gagebilt.com / www.gagebilt.com

Type:		Fasteners:	Recommended Tool: GB713	
Non Self-Releasing 3/16 & 1/4 Ø		MAGNA-GRIP® Maxlok®	Alternate Tools: GB722 & GB2480(A)	
Ref. No.	Qty.	Description	MG06-722-60	MG08-722-60
1	1	Anvil & Holder Assy	16007	18877
2	1	Anvil	16634	18872
3	1	Holder	12241-5	12241-6
4	1	Collet	20636	20841
5	1	Super-Grip Jaw Assy	30652-S	30860-S
6	1	Extension-Collet	70822	70822
7	1	O'Ring	400778	400778

MAGNA-GRIP® IS A REGISTERED TRADEMARK OF ARCONIC INC. MAXLOK® IS A REGISTERED TRADEMARK OF AVDEL UK LIMITED. VIBRA-TITE® IS A REGISTERED TRADEMARK OF OAKLAND CORPORATION.