

# NOSE ASSEMBLY DATA SHEET

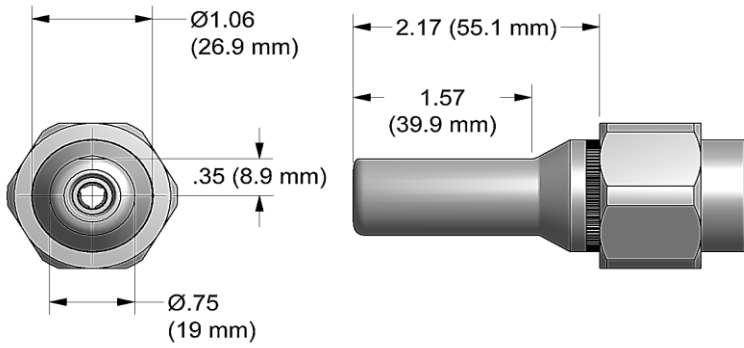

## ASSEMBLY:

**Note:** If nose assy is assembled as it is when purchased new, follow steps 3-5 to attach to tool.

1. Insert super grip jaw assy (3) into rear of collet (2). (Note direction in exploded view).
2. Thread collet (2) to extension-collet (4) using flats provided.
3. Thread assembled collet (2) and extension-collet (4) onto piston of tool using flats provided and hex in rear of piston.
4. Slide anvil assy (1) over collet (2).
5. Slide retaining nut stop and retaining nut over ears on anvil (see exploded view) and tighten to tool.

## DISASSEMBLY:

Reverse assembly instructions.

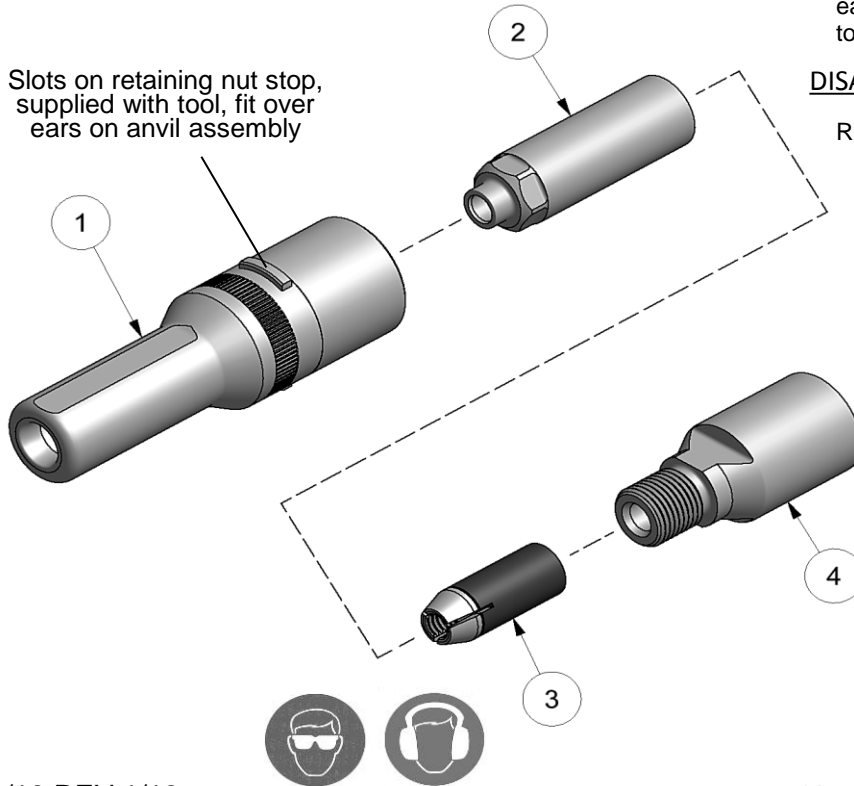

1/16 REV 1/18

\*Anvil Assembly includes 35308 retainer.

**GAGE BILT**  
MADE in USA

44766 Centre Court Clinton Twp. MI 48038 USA  
Ph: +1 (586) 226-1500 Fax: +1 (586) 226-1505  
solutions@gagebilt.com / www.gagebilt.com

Type:		Fasteners:	Recommended Tool: GB745
Non Self-Releasing 1/4" Ø		NAS Shear and NAS Tension Pull Type Lockbolts, C6L® & GP® Lockbolts	Alternate Tools: GB756 & GB2581(A)
Ref. No.	Qty.	Description	NAS08-2581-23
1	1	*Anvil Assy	18801
2	1	Collet	28842
3	1	Super-Grip Jaw Assy	30858-S
4	1	Extension-Collet	70836