

U-Nuts

Speed Nut® U-Shaped

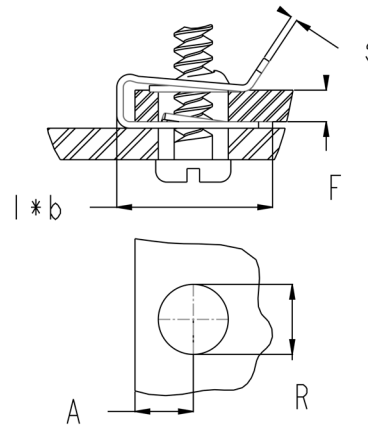

APPLICATION INFORMATION

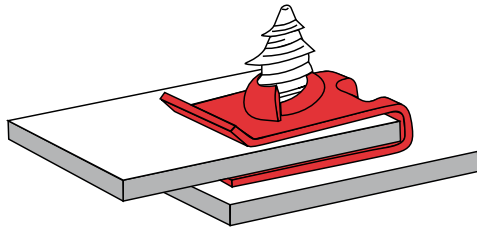

- Used to provide simple, rapid attachment of mating panels
- Parts self-retain in screw-receiving position
- Self-retention feature improves assembly time and eliminates costly welding and clinching costs
- Corrects misalignment in panel mounting holes
- Part does not turn as the screw is driven and will not freeze on screw threads
- Serviceable - parts disassemble easily and reliably
- Can be used wherever a screw or bolt is used and in place of clinch nuts and weld nuts
- Easy to assemble, requiring no special tools
- The strength of the joint greatly depends on the type of impression and screw size

DESIGN VARIATIONS



(A) STRAIGHT UPPER LEG



(C) NO RETAINER ON LOWER LEG

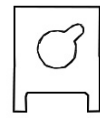

(D) RELIEF NOTCH

(J) "J" NUT

(H) BARBS ON LOWER LEGS

(3) KEYHOLE IMPRESSION



(E) CORNERS CUT OFF



(F) FULL EXTRUSION ON LOWER LEG



(G) BARB ON TOP LEG



(U) WIDE PANEL RANGE NUT

- A - No lead in. Used where space is limited
- C - Alternative retention feature on plastic panels
- D, E - Eliminate material to reduce insertion efforts
- F - Alternative retention feature for 360 degree contact
- G - Alternative or additional retention feature
- H - Alternative retention feature
- J - Alternative body form to reduce material
- U - Accommodates larger panel range
- 2 - Legacy Speed Nut® style impression
- 3 - Current keyhole impression



On Panel Edges

U-Nuts

Speed Nut® - U-Shaped

Imperial

Part Number	Legacy Part Number	Thread Specification (SS)	Panel Thickness (F)	Throat Distance (A)	Hole Diameter (R)	Width (b)	Length (l)	Material Thickness (s)	Design Variation
136594	C06227-632	6-32	0.041 - 0.051	0.156	0.187 - 0.187	0.310	0.360	0.017	2AJ
136898	C46551-011	6-32	0.018 - 0.023	0.187	0.187 - 0.187	0.312	0.370	0.011	3
137515	D11351-632	6-32	0.110 - 0.125	0.171	0.156 - 0.156	0.500	0.350	0.017	2C
137500	D08109-8	8-18 (ST4.2)	0.045 - 0.062	0.187	0.218 - 0.218	0.500	0.520	0.028	2D
136593	C06077-8Z	8-18 (ST4.2)	0.060 - 0.070	0.234	0.250 - 0.250	0.500	0.520	0.028	2AD
137623	D98448-8Z	8-18 (ST4.2)	0.091 - 0.110	0.220	0.220 - 0.220	0.423	0.417	0.024	3CH
137532	D19640-8AB	8-18 (ST4.2)	0.025 - 0.150	0.250	0.280 - 0.280	0.535	0.770	0.028	3AU
137425	D00885-8	8-18 (ST4.2)	0.037 - 0.064	0.296	0.250 - 0.250	0.437	0.630	0.028	2D
136708	C15127-8	8-18 (ST4.2)	0.168 - 0.198	0.281	0.218 - 0.218	0.406	0.610	0.028	2J
137463	D06377-8AB	8-18 (ST4.2)	0.070 - 0.150	0.312	0.328 - 0.328	0.430	0.750	0.028	2DU
137507	D09031-8	8-18 (ST4.2)	0.102 - 0.125	0.406	0.281 - 0.281	0.625	0.700	0.028	2D
137442	D01793-8	8-18 (ST4.2)	0.064 - 0.093	0.437	0.281 - 0.281	0.625	0.700	0.028	2D
137598	D97295-028	8-18 (ST4.2)	0.025 - 0.150	0.480	0.280 - 0.280	0.340	0.970	0.028	3ACU
137531	D19640-10AB	10-16 (ST4.8)	0.025 - 0.150	0.250	0.280 - 0.280	0.531	0.770	0.031	3AU
137506	D09031-10	10-16 (ST4.8)	0.102 - 0.125	0.406	0.281 - 0.281	0.625	0.700	0.031	2D
136548	C01880-10Z	10-16 (ST4.8)	0.156 - 0.187	0.750	0.281 - 0.281	0.437	1.140	0.031	2
136523	C01197-1024	10-24	0.109 - 0.120	0.281	0.312 - 0.312	0.437	0.630	0.020	2F
136619	C08048-1024	10-24	0.045 - 0.062	0.515	0.250 - 0.250	0.375	0.970	0.022	2J
136547	C01880-1024	10-24	0.156 - 0.187	0.750	0.281 - 0.281	0.437	1.140	0.020	2
137520	D13398-1032	10-32	0.045 - 0.062	0.250	0.250 - 0.250	0.625	0.570	0.017	2D
137419	D00521-1420	1/4-20	0.051 - 0.109	0.312	0.359 - 0.359	0.500	0.780	0.025	2
136707	C14969-1420	1/4-20	0.051 - 0.109	0.312	0.343 - 0.343	0.500	0.790	0.025	2F
136706	C14860-1420	1/4-20	0.064 - 0.125	0.500	0.343 - 0.343	0.500	0.970	0.025	2G
137511	D09569-1420	1/4-20	0.060 - 0.156	0.937	0.343 - 0.343	0.625	1.240	0.025	2E
137525	D17453-1420	1/4-20	0.156 - 0.190	0.906	0.343 - 0.343	0.625	1.225	0.025	2E

Metric

Part Number	Legacy Part Number	Thread Specification(SS)	Panel Thickness (F)	Throat Distance (A)	Hole Diameter (R)	Width (b)	Length (l)	Material Thickness (s)	Design Variation
137375	C71784-M42141	ST4.2 (8-18)	2.00 - 3.00	6.00	7.00 - 7.00	12.00	13.50	0.71	2DG
137939	D99228-M42141	ST4.2 (8-18)	0.60 - 2.00	7.00	7.90 - 7.90	13.00	15.00	0.71	3DKU
138972	US 420014	ST4.2 (8-18)	2.25 - 3.00	7.20	5.80 - 5.80	9.30	12.90	0.60	3
138973	US 420519	ST4.2 (8-18)	0.65 - 3.80	8.64	6.98 - 6.98	13.60	19.30	0.67	3DU
137679	D98712-064M	ST4.2 (8-18)	2.20 - 3.10	10.00	8.00 - 8.00	14.50	17.60	0.64	3D
137662	D98665-071M	ST4.2 (8-18)	1.00 - 1.27	12.70	7.92 - 7.92	14.98	20.95	0.71	4J
137370	C71743-M47159	ST4.8 (10-16)	2.46 - 2.66	6.80	7.00 - 7.00	12.70	14.10	0.64	3JZ

Most parts manufactured in spring steel